

使用说明:

- A)、请按照说明书, 正确安装、摆放设备连接供水、排水管。在安装现场预留10mm的额外空间, 以满足安装要求。(风冷设备, 需要更多的空间, 以满足空气流通和热量排出)。
- B)、冰的产出取决于环境温度和水的温度。
- C)、可选配3cm、6cm、10cm、15cm高底脚。

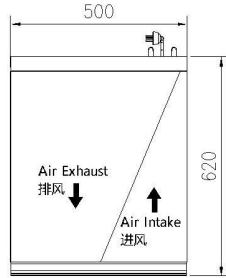

Using instruction:

- A)、Please follow the instructions, properly install and place the equipment connect the water supply pipe, drain pipe, and reserve additional space 10mm at the installation site to meet the installation requirements. (Air cooling equipment needs more space to meet the air flow and heat discharge.
- B)、The production of ice depends on the ambient temperature and the temperature of the water.
- C)、Optional 6cm 10cm 15cm adjustable feet.

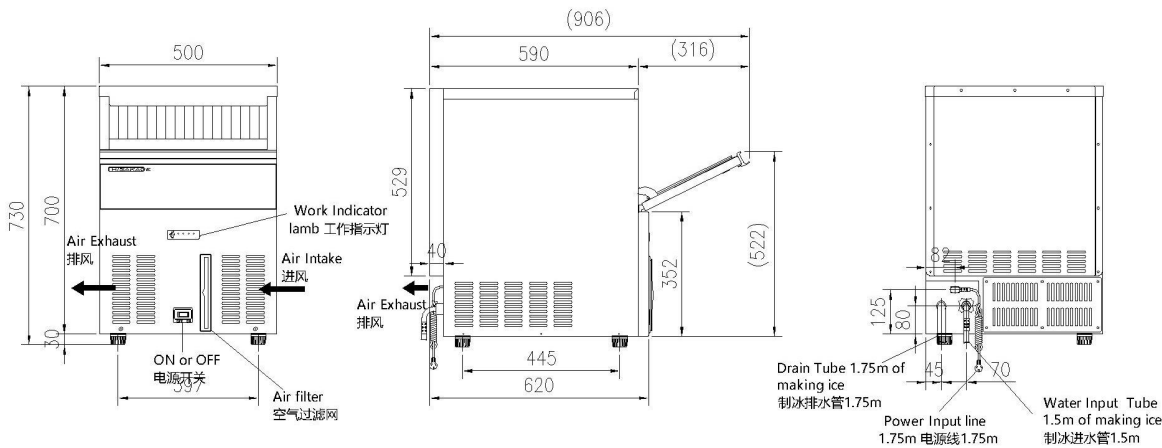

Item 名称	Commercial Ice Maker 商用制冰机
Model 型号	EC-80
使用环境 Useing range	/
Voltage 电源	220v/±10% 50Hz
Power 额定功率	460w
Capacity 制冰能力	45kg/24h
	Air temp 环温20°C, Water temp 水温15°C
	36kg/24h
	Air temp 环温20°C, Water temp 水温15°C
Ice Type 冰形	Cylindrical 圆冰
Ice Size 冰块尺寸	25*30*30
Storage 储冰量	20kg
Work Water Consumption 制冰耗水量	45kg/24h
Condensing Water Consumption 冷凝耗水量	/
Outside Material 外壳钣金材料	304ss
Ice Bin Material 储冰筒材料	PE
Insulation Material 保温材料	Cyclopentane 环戊烷
Ice Falling Mode 落冰方式	Heat Pump+Flow 热泵+流水
Water Feeding 进水方式	4Inch (R1/2)direct feeding water 4分R1/2直接供水
Drainage Mode 排水方式	AD25Inch Drain-pipe With Cleaning AD25排水管, 带清洗
Power Connection Mode 电源连接方式	Power Cord Direct Connection 电源线直连
Water Supply Connection Mode 供水连接方式	AD4 Inch Water pipe,R1/2 Threaded Valve 4分 (R1/2)螺纹连接
Drainage Connection Mode 排水连接方式	Nature Flow 排水管, 自然流出
Compressor Type 压缩机类型	Enclosed Unit 全封闭式压缩机
Condensing System 冷凝器型式	Forced air cooling 强制风冷
Refrigerant Throttle 制冷剂节流方式	Capillary tube 毛细管
Refrigerant Type/weight 制冷剂类型/重量	R404a/300g
Ice Making Control 制冰控制系统	PC Board Control 主板控制
Defrosting Control System Mode 掉冰/除霜控制方式	Mechanical Switch+ Delay Switch 机械开关+延时控制
Ice-Filled Control Mode 冰满控制方式	magnetic switch 光电开关
Water Level Control Method 水位控制方式	Water float机械浮球
Electrical Protection 电器保护方式	6.3a Fuse Wire 6.3A保险丝
Compressor Protection Mode 压缩机保护方式	High voltage protection/2.8mpa 高压保护
Dimension 外形尺寸:	500*620*795
Packing size 包装尺寸:	590*710*885
N.W/GW 净重/毛重:	/
Spare Parts With Machine 随机附件	Ice Shovel, Inlet Pipe, Drain Pipe 冰铲、进水管、排水管

Approved by European Ce and Cb.
本产品已通过CE, CB认证。

HISAKAGE [®]	Cylindrical 圆冰	EC-80	View Orientation 视图方向	俯	T	Revise Date 修订日期	Make Date 制日期	REV A
				正	后	F L B /	2019-05-09	

Remark : Product update and modify, there are different between original product and picture, pictures only for reference, the right of final interpretation belong to Hisakage.
备注: 产品改造升级, 实物与原图有差异, 图片仅供参考, 久景为最终解释权。